

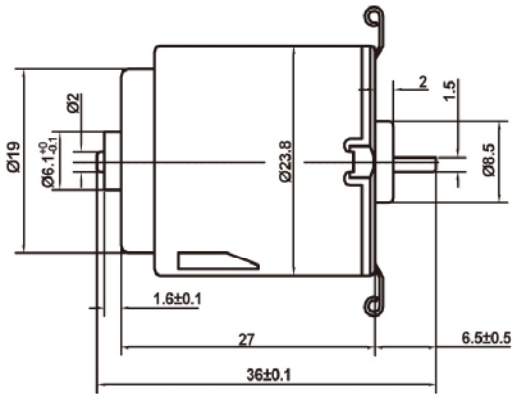

Model	Voltage		No Load		At Maximum Efficiency				Stall			
	Operating Range	Nominal	Speed	Current	Speed	Current	Torque		Output	Torque		Current
			RPM	A	RPM	A	g.cm	mN.m	W	g.cm	mN.m	A
LDM-260DP	3~9VDC	6.0VDC	2200	0.018	1730	0.067	11.6	1.13	0.31	55	5.4	0.25
LDM-260DP	9~15VDC	12.0VDC	6000	0.07	4600	0.23	24.5	2.4	1.16	105	10.2	0.75

**Drawing**

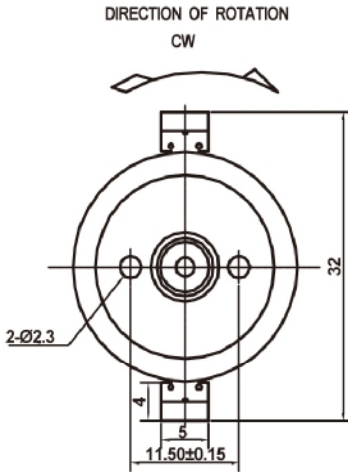

WEIGHT:30g

上述尺寸单位:mm

**Performance Curve**

**Description**

LDM-260DP

——12.0V

Application: Car

典型应用: 汽车

P. S. :

The above motor performance is only for reference purposes. We can design the motors according to customers' requirements of specific motor parameters, shaft length, lifetime etc.

备注:

上述电机性能仅供参考, 具体电机性能参数, 轴长, 寿命要求, 各项认证要求可根据客户的实际要求进行设计。

