

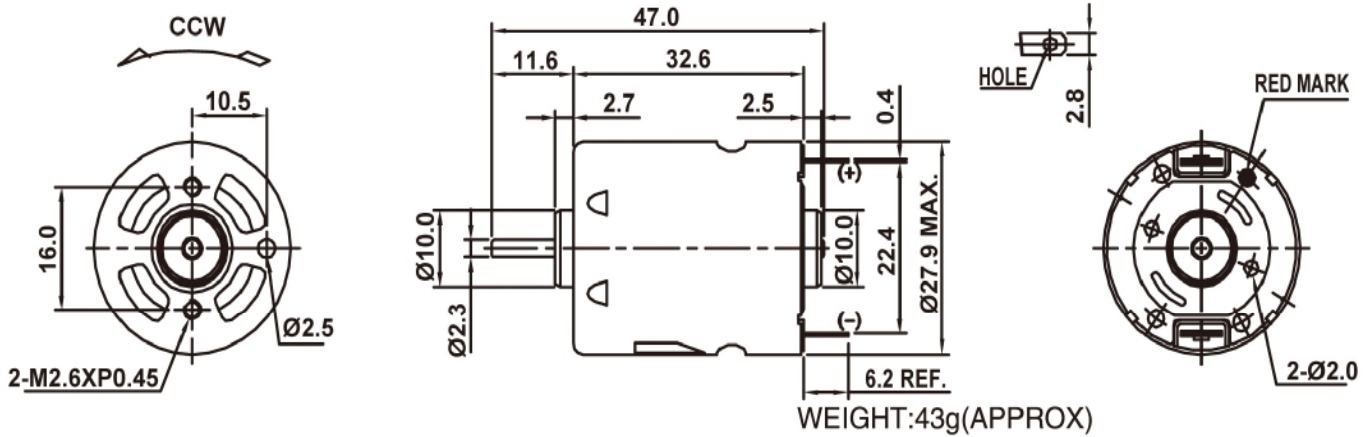

Model	Voltage		No Load		At Maximum Efficiency				Stall			
	Operating Range	Nominal	Speed	Current	Speed	Current	Torque		Output	Torque		Current
			RPM	A	RPM	A	g.cm	mN.m	W	g.cm	mN.m	A
LDM-360SH-10490	12~30V	24V Constant	7000	0.05	5600	0.19	45.0	4.41	2.59	230.0	22.54	0.78
LDM-365SH-20080	2.0~20V	20V Constant	21500	0.24	17600	1.12	77.0	7.55	13.95	433.5	42.48	5.17

Drawing

DIRECTION OF ROTATION



上述尺寸单位:mm

Performance Curve

Description

LDM-360SH-10490

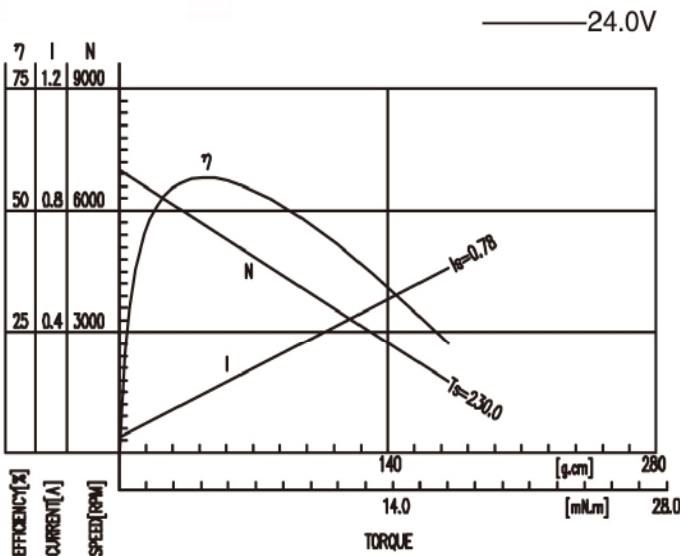

Application:

Hair dryer, paper shredder, electric tools
 air pump, water pump, household appliances.
 personal care products.

典型应用:

吹风机, 碎纸机, 电动工具
 气泵, 水泵, 家用电器等。

P. S. :

The above motor performance is only for reference purposes. We can design the motors according to customers' requirements of specific motor parameters, shaft length, lifetime etc.

备注:

上述电机性能仅供参考, 具体电机性能参数, 轴长, 寿命要求, 各项认证要求可根据客户的实际要求进行设计。