

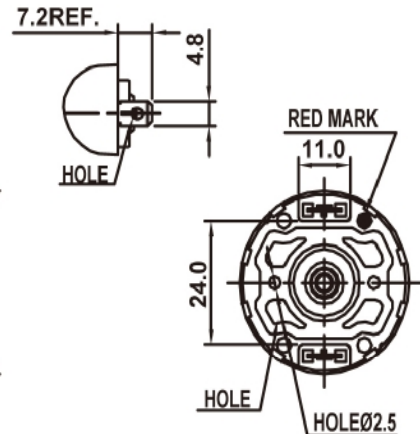

Model	Voltage		No Load		At Maximum Efficiency				Stall			
	Operating Range	Nominal	Speed	Current	Speed	Current	Torque	Output	Torque	Current		
			RPM	A	RPM	A	g.cm	mN.m	W	g.cm	mN.m	A
LDM-530SH-20095	4.8~24V	12.0V Constant	7850	0.25	6200	0.90	85.9	8.42	5.42	396.5	38.9	3.27
LDM-530SH-10280	12~36V	24.0V Constant	5200	0.08	3800	0.23	63.3	6.2	2.5	245.8	24.1	0.67

Drawing

DIRECTION OF ROTATION

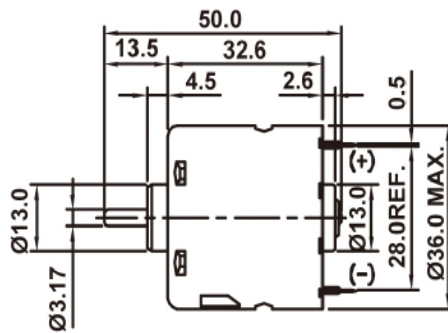
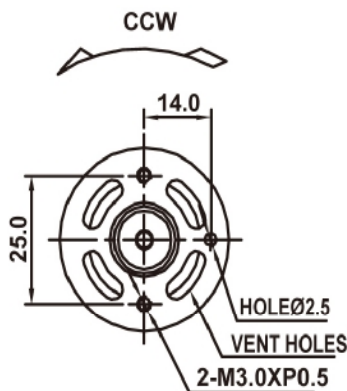

WEIGHT:95g(APPROX)

上述尺寸单位:mm

Performance Curve

LDM-530SH-20095

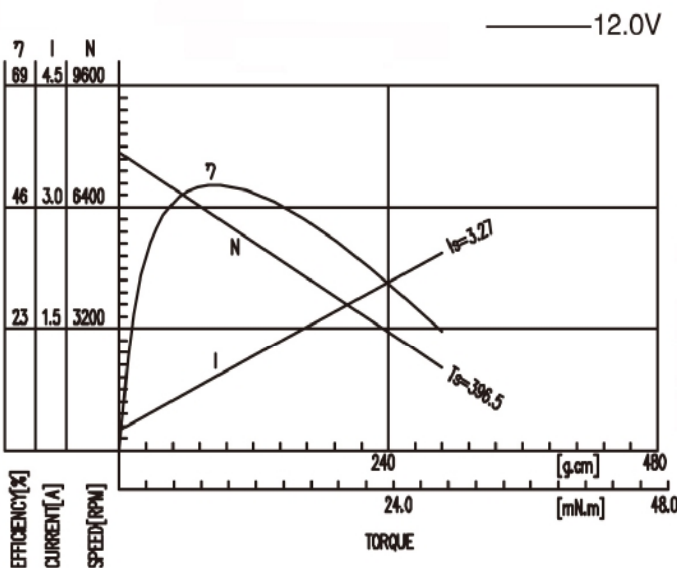

Description

Application:

Cordless electric toys, electric tools, hair dryer, vacuum cleaner, multi-mixer, Food processor, Household appliances, Air pump, water pump, etc.

典型应用

无绳电动玩具, 电动工具, 吹风机, 吸尘器, 搅拌机等家用电器, 气泵, 水泵等。

常用的标准轴长: 50/57/67mm

P. S. :

The above motor performance is only for reference purposes. We can design the motors according to customers' requirements of specific motor parameters, shaft length, lifetime etc.

备注:

上述电机性能仅供参考, 具体电机性能参数, 轴长, 寿命要求, 各项认证要求可根据客户的实际要求进行设计。