

Step Accuracy-----±5%
 Temperature Rise-----80°C Max.
 Ambient Temperature Range-----20°C~+50°C
 Insulation Resistance-----100MΩ Min.50V DC
 Dielectric Strength-----500V AC 1minute

电机型号Model	步距角 Step Angle (°)	机身長 Motor length (mm)	相电压 Rate voltage (V)	相电流 Rate current (A)	相电阻 Phase resistance (Ω)	相电感 Phase inductance (mH)	静力矩 Holding torque (N.cm)	引线数 Lead wire (NO.)	定位力矩 Detent torque (Kg.cm)	转动惯性 Rotor inertia (Kg.cm)	重量 motor weight (Kg)
110BYGH99-001	1.8	99	4.95	5.5	0.9	12	11.2	4	5	5.5	5
110BYGH150-001	1.8	150	5.44	6.8	0.8	15	21	4	8.4	10.9	8.4
110BYGH201-001	1.8	201	5.36	8	0.67	12	18	4	11.7	16.2	11.7

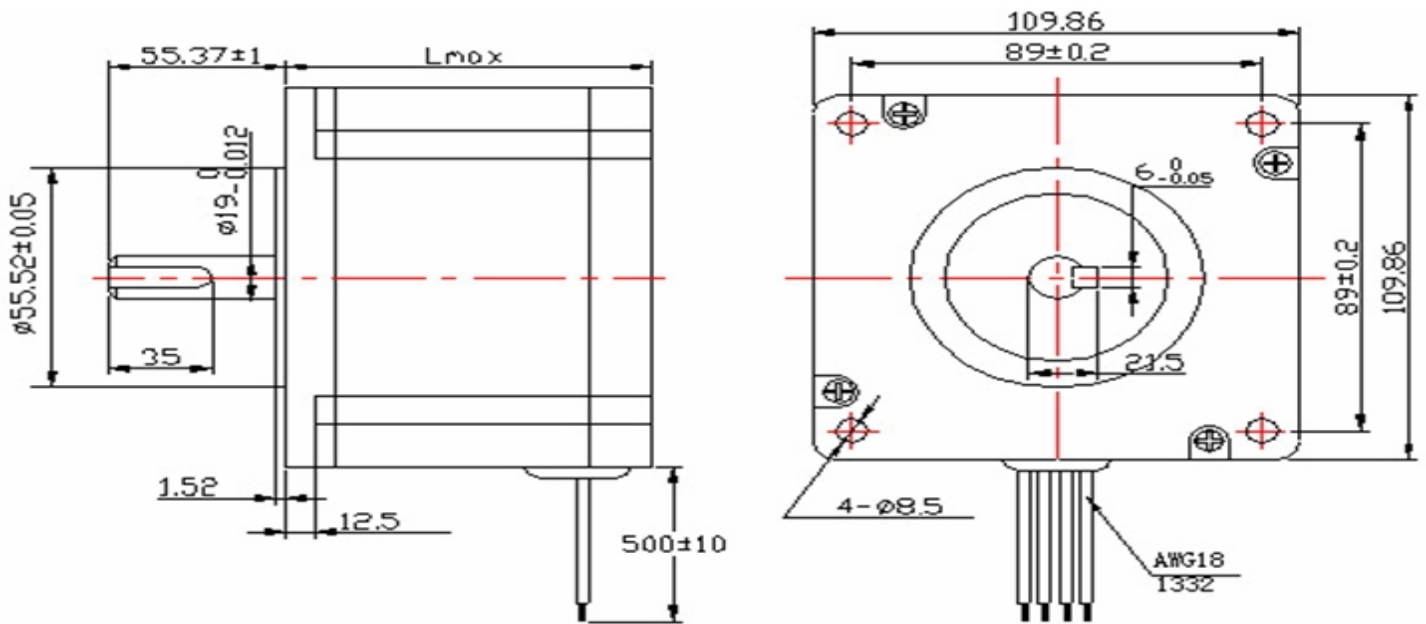

Wiring Diagram (接线图)

