

Step Accuracy-----±5%
 Temperature Rise-----80°C Max.
 Ambient Temperature Range-----20°C ~+50°C
 Insulation Resistance-----100MΩ Min. 50V DC
 Dielectric Strength-----500V AC 1minute

电机型号 Model	步距角 Step angel (°)	机身長 Motor Length L(mm)	相电压 Rate Voltage (V)	相电流 Rate Current (A)	相电阻 Phase Resistance (Ω)	相电感 Phase Inductance (mH)	静力矩 Holding Torque (g. cm)	引线数 Lead Wire (NO.)	转动惯量 Rotor Inertia (g. cm ²)	定位力矩 Detent Torque (g. cm)	重量 Motor Weight (kg)
39BYGHM207	0.9	26	12	0.5	24	13	1000	6	11	95	0.15
39BYGHM209	0.9	26	4.25	0.425	10	15	800	4	11	95	0.15

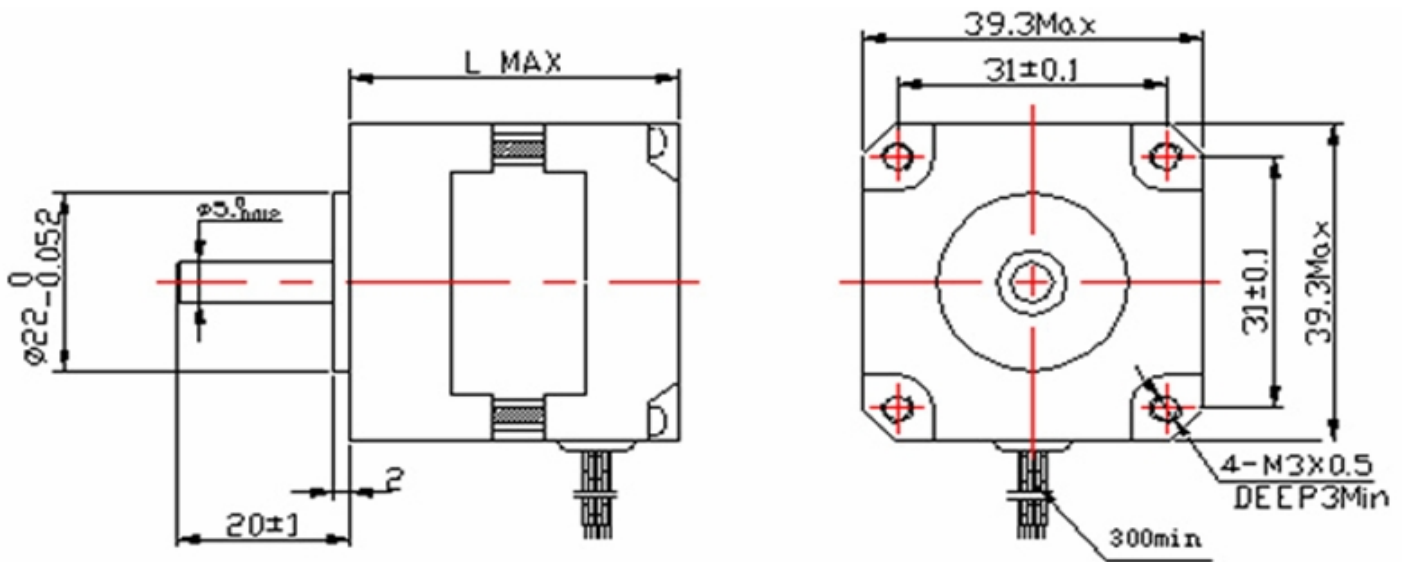

Wiring Diagram (接线图)

