

Step Accuracy-----±5%
 Temperature Rise-----80°C Max.
 Ambient Temperature Range-----20°C~+50°C
 Insulation Resistance-----100MΩ Min.50V DC
 Dielectric Strength-----500V AC 1minute

电机型号 Model	步矩角 Step angel (°)	机身长 Motor Length L (mm)	相电压 Rate Voltage (V)	相电流 Rate Current (A)	相电阻 Phase Resistance (Ω)	相电感 Phase Inductance (mH)	静力矩 Holding Torque (kg. cm)	引线数 Lead Wire (NO.)	转动惯量 Rotor Inertia (g. cm ²)	定位力矩 Detent Torque (kg. cm)	重量 Motor Weight (kg)
60BYGH801A	1.8	87	10	2	2.8	6	1.8	6	840	1.1	1.34
60BYGH805A	1.8	87	5.6	4	0.7	3.5	2.3	4	840	1.1	1.34
60BYGH806A	1.8	87	3.75	3	1.4	4.3	2.0	6	840	1.1	1.34

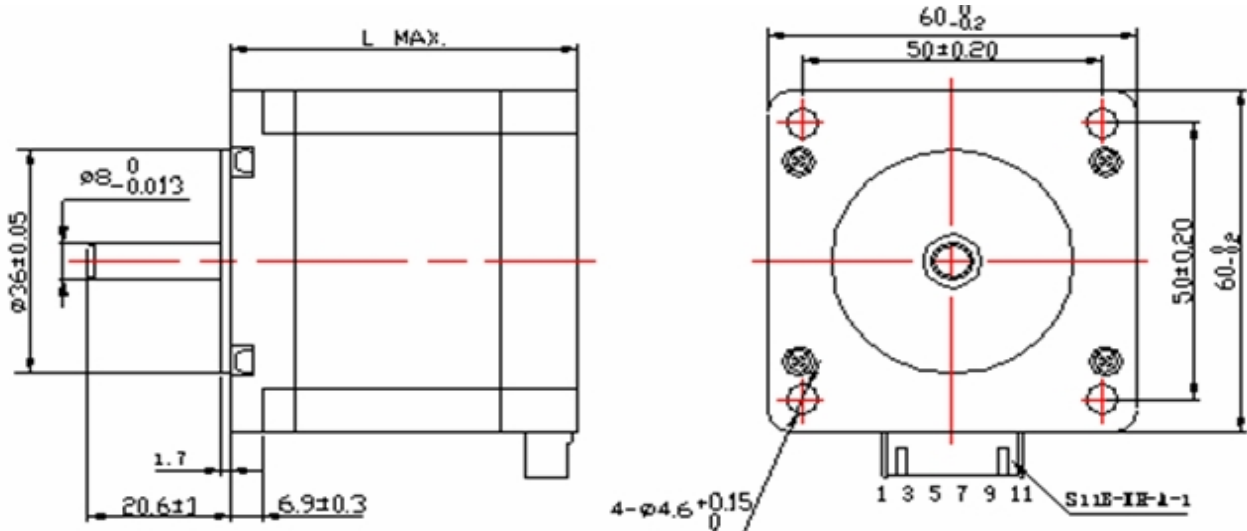

Wiring Diagram (接线图)

