

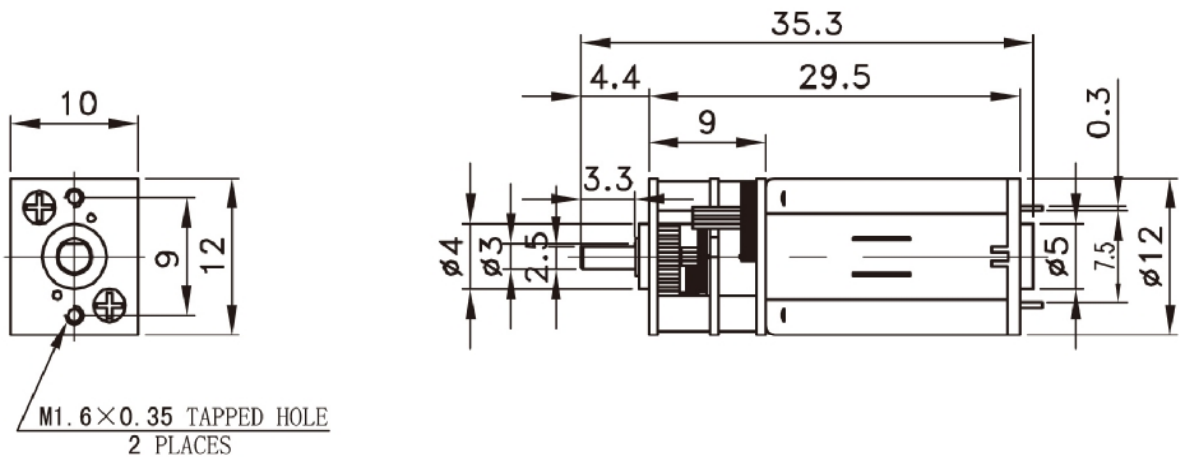

Model	Voltage		No Load		At Maximum Efficiency				Stall			
	Operating Range	Nomimal	Speed	Current	Speed	Current	Torque		Output	Torque		Current
			RPM	A	RPM	A	g.cm	mN.m	W	g.cm	mN.m	A
LDM-12GM	1.2-6VDC	2.5VDC	17	0.025	13	0.09	310	30.3	0.04	1350	132.3	0.25
LDM-12GM	3-9VDC	6VDC	30	0.045	22	0.13	620	60.8	0.14	2300	225.5	0.36

**Drawing**

LDM-12GM



WEIGHT:9g(APPROX)

上述尺寸单位:mm

**Performance Curve**

**Description**

LDM-12GM

——6.0V

Application:

典型应用

Robot, High-quality toys, electronic lock, camera, etc.

- 1.机器人玩具
- 2.电子门锁

P. S. :

The above motor performance is only for reference purposes. We can design the motors according to customers' requirements of specific motor parameters, shaft length, lifetime etc.

备注:

上述电机性能仅供参考, 具体电机性能参数, 轴长, 寿命要求, 各项认证要求可根据客户的实际要求进行设计。

