

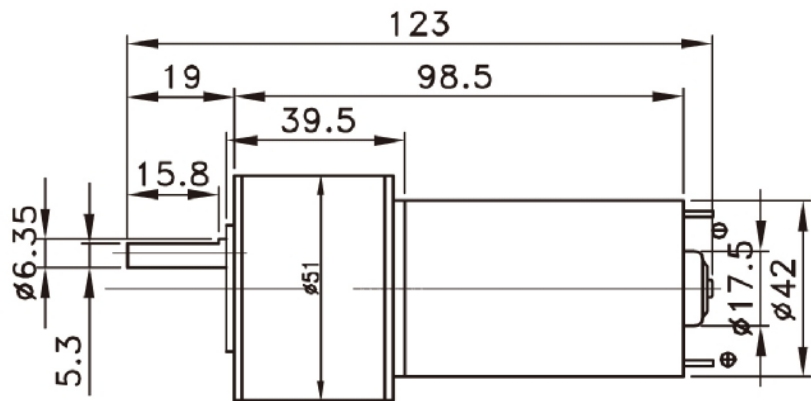

Model	Voltage		No Load		At Maximum Efficiency				Stall			
	Operating Range	Nominal	Speed	Current	Speed	Current	Torque		Output	Torque		Current
			RPM	A	RPM	A	g.cm	mN.m	W	g.cm	mN.m	A
LDM-51GM	3~30VDC	24.0VDC	72	0.35	58	1.51	15000	1476.4	9.02	80000	7543.1	6.5
LDM-51GM	3~12VDC	12.0VDC	31	0.8	25	3.4	51350	5034.3	13.2	270000	25470.5	14.5

Drawing

LDM-51GM

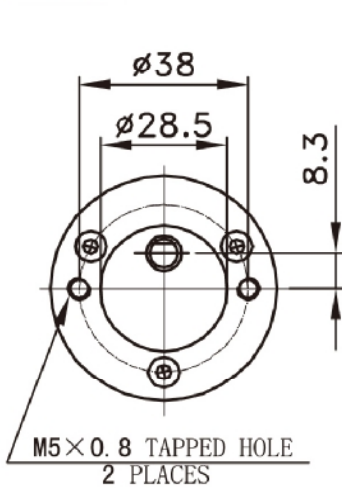

WEIGHT:489.2g(APPROX)

上述尺寸单位:mm

Performance Curve

LDM-51GM

——24.0V

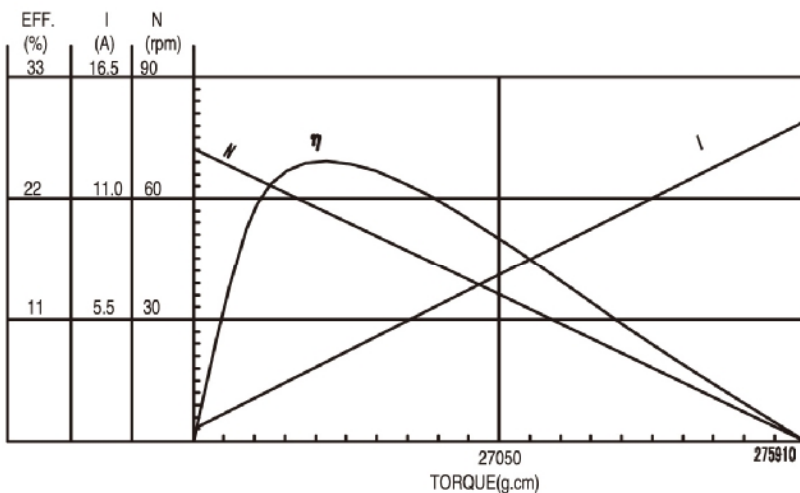

Description

Application:

Automation equipment, ATM machine, vending machines, coffee machine, shredder, etc.

P. S. :

The above motor performance is only for reference purposes. We can design the motors according to customers' requirements of specific motor parameters shaft length, lifetime etc.

备注:

上述电机性能仅供参考, 具体电机性能参数, 轴长, 寿命要求, 各项认证要求可根据客户的实际要求进行设计。